

**GRAIN (FLOUR)
MOISTURE METER**

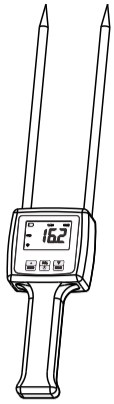

TK100GF

VER.1403100G11

The Grain Moisture Meter TK100GF is used for fast and accurate measurement of moisture in the process of allotment, acquisition, storage, machining of packed grains flour, including Wheat, Paddy, Corn, Flax, Oats...

2.Specification

Display:4 digital LCD
 Measuring range :6-30%
 Operating conditions:
 Temperature: 0-60°C
 Humidity: <85%RH
 Resolutions: 0.1
 Accuracy: ±0.5%n
 Operating principle:
 Electrical conductivity,
 Automatic temperature
 Compensation
 Power supply:
 4x1.5 AAA size (UM-4) battery
 Dimensions:
 460x75x35mm
 18.3x3x1.4 inch
 Weight:
 203g (not including batteries)

4.5 When the reading is big difference with the actual value, please depress "Fun" key and not release until "Adj" showed on display, then press ▲ or ▼ key to adjust the value, and then depress "Fun" key back to the measurement state.

5.Warning setting

5.1 Depressing "Fun" key and don't release until "AL2" showed on display(it will takes 7 seconds to complete operation),then press ▲ or ▼ key to choose your suitable value according to your need, press the "Fun" key again back to the operation state.

1.Features:

- 1.1.It is portable, compact, easy to use and the moisture measurement readings are instant.
- 1.2.Digital display with back light gives exact and clearly reading although you stay at the somber conditions.
- 1.3.It will save time and expense by monitoring dryness and helps to prevent deterioration & decay caused by moisture whilst in storage, therefore processing will be more convenient and efficient.
- 1.4.The moisture meter operates by electrical

3.Panel descriptions

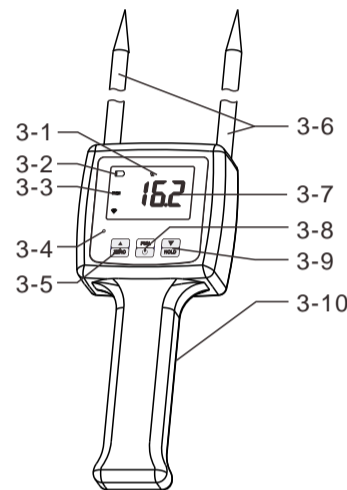

- 3-1 % symbol
- 3-2 low battery
- 3-3 max symbol
- 3-4 warning light
- 3-5 zero/inc key
- 3-6 pin probe
- 3-7 testing value
- 3-8 power/function key

3-10 hold /dec key 3-11 battery cover

4.Operation procedure

- 4.1 Turn on the power key ,the symbol "0.0"will be showed on display. It will need zeroing if showed other value, please depress ZERO key while the probe sensor without touch anything, or zeroing is not efficient. make zeroing can decrease the effect from the temperature and humidity in the air.
- 4.2 Hold the instrument with your hand, insert the probes into the materials straightly.

Thanks for choosing our moisture meters!
 For your easy to master this instrument as soon as possible, please read following instructions carefully and always keep this meter within easy reach.

- into the materials straightly. The probes are more deeper, the value is better.
- 4.3 Depress Hold key,the symbol "max"will be showed on display, then the max value must be stored on display when measuring. Depress the key again, this function will be canceled.
- 4.4 Choose the suitable code for different grain. Depress the key and not release until the "CDXX" showed on display, then press ▲ or ▼ key to choose your needed code. Please refer to the table in 8.0

- 5.2 Setting the "AL1" just the same ways as "AL2".
- 5.3 Usually ,"AL2"must larger than "AL1",if the "AL2" less than "AL1" during setting will be returned back the factory setting, just to say,AL1=13,AL2=18.

6.Replace batteries

When battery symbol showed on display, it must replace the batteries in time. Slide the batteries cover ,put the batteries into the hole correctly.

7.Notes:

Please take out the batteries if the instruments without use for a long time. Put the probe in the air without touch anything when zeroing, or the zeroing is not efficient.

8.Code table

CODE	GRAIN
Cd01	Wheat/Rye
Cd02	Paddy
Cd03	Maize/Corn
Cd04	Semolina
Cd05	Soya Beans
Cd06	Barley/Oats
Cd07	Coffee
Cd08	Sorghum/Milo
Cd09	Flax
Cd10	Peas
Cd11	Flour/Soft