

## HAY MOISTURE METER

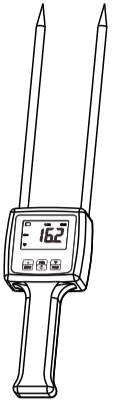

TK100H





All right reserved 2011

The Hay Moisture Meter TK100H is suits to many hays moisture content testing, just as alfalfa, leymus chinensis, orchard grass pennisetum hydridum and other Hays.

### 2.Specification

Display:4 digital LCD  
 Measuring range :0-80%(CD00)  
 Operating conditions:  
 Temperature:-10~60°C  
 Humidity:5%~90%RH  
 Resolution:0.1  
 Accuracy: ± 0.5%n  
 Operating principle:  
 Electrical conductivity,  
 Automatic temperature  
 Compensation  
 Power supply:  
 4x1.5 AAA size (UM-4) battery  
 Dimensions:  
 460x75x35mm  
 18.3x3x1.4 inch  
 Weight:  
 203g (not including batteries)

### 5.Warning setting

5.1 Depressing  key and don't release until "AL2" showed on display(it will takes 5 seconds to complete operation),then press key  or  to choose your suitable value according to your need, press  key again back to the operation state.  
 5.2 Setting the "AL1" just the same ways as "AL2".  
 5.3 Usually , "AL2" must larger than "AL1", if the "AL2" less than "AL1" during setting process, then the instrument

### 1.Features:

- 1.1.It is portable, compact, easy to use and the moisture measurement readings are instant.
- 1.2.Digital display with back light gives exact and clearly reading although you stay at the somber conditions.
- 1.3.It will save time and expense by monitoring dryness and helps to prevent deterioration & decay caused by moisture whilst in storage, therefore processing will be more convenient and efficient.
- 1.4.The moisture meter operates by electrical

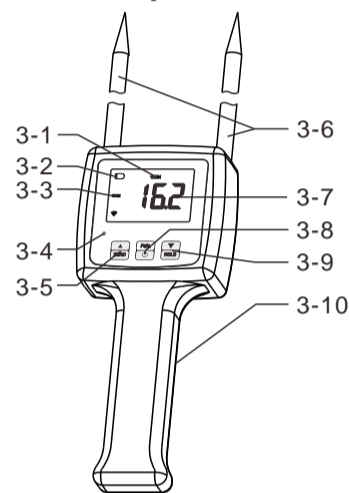

### 3.Panel descriptions







- 3-1 % symbol
- 3-2 low battery
- 3-3 max symbol
- 3-4 warning light
- 3-5 zero/inc key
- 3-6 pin probe
- 3-7 testing value

- 3-8 power/function key
- 3-9 hold /dec key
- 3-10 battery cover

### 4.Operation procedure

- 4.1 Turn on the  key ,the symbol "0" will be showed on display. It will need zeroing if showed other value, please depress  key while the probe sensor without touch anything, or zeroing is not efficient. make zeroing can decrease the effect from the temperature and humidity in the air.
- 4.2 Hold the instrument with your hand, insert the probes

Thanks for choosing our moisture meters!  
 For your easy to master this instrument as soon as possible, please read following instructions carefully and always keep this meter within easy reach.

- into the materials straightly. The probes are more deeper, the value is better.
- 4.3 Depress  key ,the symbol "max" will be showed on display, then the max value must be stored on display when measuring. Depress the  key again, this function will be canceled.
  - 4.4 Choose the suitable code for different hays. Depress the  key and not release until the "CDXX" showed on display, then press  or  key to choose your

needed code. Please refer to the table in 8.0

will be returned back the factory setting, just to say, AL1=13, AL2=18.

### 6.Replace batteries

When battery symbol  showed on display, it must replace the batteries in time. Slide the batteries cover ,put the batteries into the hole correctly.

### 7.Notes:

Please take out the batteries if the instruments without use for a long time.  
 Put the probe in the air without touch anything when zeroing, or the zeroing is not efficient.

### 8.Reference Code Table

CODE	Hays
Cd00	Straw /General
Cd01	Guinea grass /Clover
Cd02	Soap wort
Cd03	Wheat Straw

Please choose the code according to your true conditions, and the default code is CD00.