

**GRAIN
MOISTURE METER**

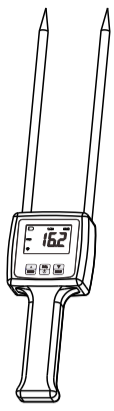

TK25G

VER170D08

The Grain Moisture Meter TK25G is used for fast and accurate measurement of moisture in the process of allotment, acquisition, storage, machining of packed grains, Barley, Corn, Hay, Oats, Rapeseed, Rough Rice, Sorghum, Soybeans and Wheat.

2.Specification

Display:4 digital LCD
 Measuring range :6-30%
 Operating conditions:
 Temperature:0-60°C
 Humidity:5%-90%RH
 Resolution:0.1
 Accuracy: ± 0.5%n
 Operating principle:
 Electrical conductivity,
 Automatic temperature
 Compensation
 Power supply:
 4x1.5 AAA size (UM-4) battery
 Dimensions:
 460x75x35mm
 18.3x3x1.4 inch
 Weight:
 203g (not including batteries)

Thanks for choosing our moisture meters!
 For your easy to master this instrument as soon as possible, please read following instructions carefully and always keep this meter within easy reach.

1.Features:

- 1.1 It is portable, compact, easy to use and the moisture measurement readings are instant.
- 1.2 Digital display with back light gives exact and clearly reading although you stay at the somber conditions.
- 1.3 It will save time and expense by monitoring dryness and helps to prevent deterioration & decay caused by moisture whilst in storage, therefore processing will be more convenient and efficient.
- 1.4 The moisture meter operates by electrical

- conductivity and has automatic temperature compensation.
- 1.5 Measurements are taken by inserting the sensors into the bale of grains .
- 1.6 Manual off at any time . Auto power off after 5 minutes from last operation.

3.Panel descriptions

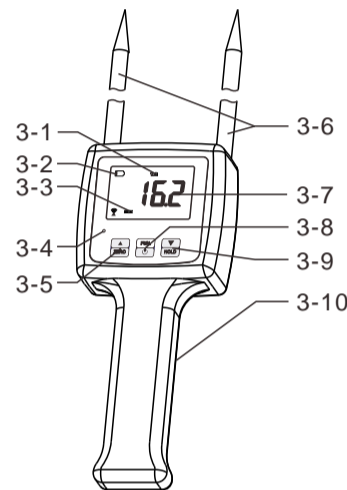

- 3-1 % symbol
- 3-2 low battery
- 3-3 max symbol
- 3-4 warning light
- 3-5 zero/inc key
- 3-6 pin probe
- 3-7 testing value
- 3-8 power/function key
- 3-9 hold /dec key
- 3-10 battery cover

4.Operation procedure

- 4.1 Turn on the key , the symbol "0" will be showed on display. It will need zeroing if showed other value, please depress key while the probe sensor without touch anything, or zeroing is not efficient. make zeroing can decrease the effect from the temperature and humidity in the air.
- 4.2 Hold the instrument with your hand, insert the probes into the materials

straightly .The probes are more deeper ,the value is better.

- 4.3 Depress key, the symbol "max" will be showed on display, then the max value must be stored on display when measuring. Depress the key again, this function will be canceled.
- 4.4 Choose the suitable code for different grain. Depress the key and not release until the "CDXX" showed on display, then press or key to choose your

needed code. Please refer to the table in 8.0

5.Warning setting

- 5.1 Depressing key and don't release until "AL2" showed on display(it will takes 5 seconds to complete operation),then press key or to choose your suitable value according to your need, press key again back to the operation state.
- 5.2 Setting the "AL1" just the same ways as "AL2".
- 5.3 Usually ,"AL2" must larger than "AL1",if the "AL2" less than "AL1" during setting

process, then the instrument will be returned back the factory setting, just to say, AL1=13,AL2=18.

6.Replace batteries

When battery symbol showed on display, it must replace the batteries in time. Slide the batteries cover ,put the batteries into the hole correctly.

7.Notes:

- 7.1 Please take out the batteries if the instruments without use for a long time.
- 7.2 Put the probe in the air without touch anything when

zeroing, or the zeroing is not efficient.

- 7.3 When the reading is big difference with the actual value, please depress key and not release until "Adj" showed on display, then press or key to adjust the value, and then depress FUN key back to the measurement state.

8.Code table

CODE	GRAIN
Cd01	Wheat/Rye
Cd02	Maize/Corn
Cd03	Soya Beans
Cd04	Paddy
Cd05	Rice
Cd06	Barley/Oats
Cd07	Sorghum/Milo
Cd08	Buckwheat
Cd09	Peas
Cd10	Oilseed Rape
Cd11	Mustard Seed

CODE	GRAIN
Cd12	Sunflower seed
Cd13	Sugarbeet Seed
Cd14	Coffee
Cd15	Coffee Green
Cd16	Cocoa Beans
Cd17	Linseed
Cd18	Lentils
Cd19	Ground nuts Hulled
Cd20	Grass Seed/Rye grass
Cd21	Grass Seed/Cocksfoot
Cd22	Clover/White Seed

CODE	GRAIN
Cd23	Clover/Red Lucerne Seed
Cd24	Brassicas/ Brussels Sprout, Cabbage seed
Cd25	Beans/Tic /Winter